

PEX8605 Highlights

■ PEX8605 Vitals

- 4-lane, 4-port PCIe Gen2 switch
 - Integrated 5.0 GT/s SerDes
- 10 x 10mm², 136-pin QFN package
- Typical Power: 0.8 Watts

■ PEX8605 Key Features

- **Standards Compliant**
 - PCI Express Base Specification, r2.1 (backwards compatible w/ PCIe 1.0a/1.1)
 - PCI Power Management Spec, r1.2
 - Microsoft Windows 7 Compliant
 - Dynamic SerDes speed control
- **High Performance**
 - Non-blocking switch fabric
 - Full line rate on all ports
 - Packet Cut-Thru with 250ns max packet latency (x1 to x1)
 - 256B Max Payload Size
- **Flexible Configuration**
 - Ports configurable as x1, x2
 - Registers configurable with strapping pins, EEPROM, I²C, or host software
 - Lane and polarity reversal
 - Compatible with PCIe 1.0a PM
- **Quality of Service (QoS)**
 - Eight traffic classes per port
 - Round-robin source port arbitration
 - Relaxed PCI Ordering
- **Reliability, Availability, Serviceability**
 - visionPAK
 - Port Performance Monitoring
 - Port payload & header counters
 - SerDes Eye Capture
 - Error Injection and Loopback
 - All ports Hot-Plug capable thru I²C (Hot-Plug Controller on every port)
 - Data Path parity
 - Memory (RAM) Error Correction signals
 - INTA# and FATAL_ERR#
 - Advanced Error Reporting
 - Port Status bits and GPIO available
 - Per port error diagnostics
 - JTAG AC/DC boundary scan
- **Power Management**
 - WAKE#, Beacon, Vaux support

Application:

Set-Top Boxes, Home Gateways

PLX Product:

PEX8605 – 4 Lane, 4 Port PCI Express Gen 2.0 Switch

Key Benefit:

Low Power, Small Package, Fan-Out

The set-top box or “cable box” was once a device that had one role: to provide cable TV content to the living room TV. With today’s numerous sources of media content and multiple media devices in the home, the set-top box of today is a much more complex device, acting as a media server, digital video recorder (DVR), home gateway to the Internet, and much more.

Today’s set-top box needs to be able to support media content coming from cable/satellite providers as well as media from the Internet (e.g. YouTube, IPTV) and from other devices in the home network (e.g. Networked Attached Storage or NAS). In addition to being a networked media serving device, the set-top box supports DVR capabilities that enable consumers to record/watch their favorite TV shows whenever they want.



With these new roles, today’s set-top box needs to be able to handle high bandwidth traffic and support multiple IOs to distribute, store, and backup data throughout the home. Although many embedded processors used in set-top boxes have started to support PCI Express (PCIe) as the high bandwidth interface, the support is limited to a x1 PCIe interface, which limits the number of features that can be added.

Simple Fan-Out for interfacing to High Speed Features

As a point-to-point protocol, a x1 PCIe interface limits the embedded processor to connect to a single device or endpoint. A PCIe switch is needed in this case to provide more IO connectivity for the set-top box/home gateway designs.

With the PLX PEX8605, 4 Lane, 4 Port, PCIe Gen 2.0 switch, easy fan-out can be achieved to allow many IOs to be connected to the limited PCIe x1 port from the embedded processor. Connecting one of the x1 ports as upstream to the embedded processor, the PEX8605 enables three more PCIe-based devices to be added to the set-top box design.

Enabling High Speed Networking and SuperSpeed USB 3.0

As mentioned, the set-top box is now, and will forever be a “connected” device. A high speed connection to the Internet and the home network will enable consumers to stream Internet media content and playback home videos from other networked devices (e.g. NAS, other PCs) in the home. Figure 1 below shows the addition of high speed networking 802.11n and Gigabit Ethernet (GbE) adapters through the PEX8605 switch.

Another PCIe endpoint that can be added is a SuperSpeed USB 3.0 host or device controller. A PCIe-based SuperSpeed USB 3.0 host controller will enable consumers to connect a USB 3.0 device such as a digital camcorder for video playback or a USB hard drive for data backup (e.g. backup recorded TV shows).

Future set-top box designs may implement a PCIe-based USB 3.0 device controller, such as PLX’s [USB3380](#), which will enable the set-top box to be connected to a PC for transferring data. Both usages will enable a screaming 5Gbps connection for the set-top box.

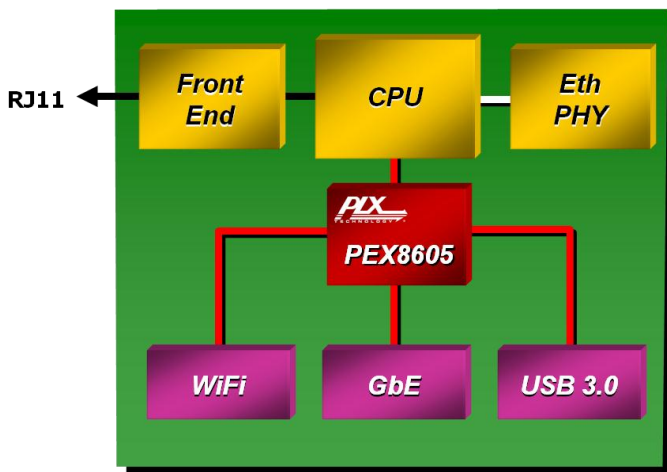

Figure 1. PEX8605 in a Set-Top Box/Home Gateway

High Performance, Low Power, and Small Package Ideal for Consumer Designs

The PEX8605 boasts unsurpassed performance with its non-blocking architecture, capable of supporting both host-centric as well as true peer-to-peer traffic on its ports. The

PEX8605 interfaces directly and seamlessly to embedded processors commonly used in consumer applications.

At 0.8W typical power, the PEX8605 provides low power capability that is fully compliant with the PCI Express power management specification. In addition, the SerDes physical links can be turned off when unused for even lower power.

The PEX8605 is one of the smallest PCIe Gen 2.0 switches in the market, at 10 x 10mm² QFN package, it is ideal for consumer applications such as the set-top box.

Development Tools & Custom Solutions

PLX offers hardware and software tools to enable rapid customer design activity. These tools consist of a hardware module (PEX 8605-AA RDK), hardware documentation (available at www.plxtech.com), and a Software Development Kit (also available at www.plxtech.com).

Rapid Development Kit (PEX8605-AA RDK)

- PEX8605 board with PCI Express configuration modules
- Reference design schematics for reduced time-to-market
- Product documentation & application notes

Software Development Kit (SDK)

- PLX’s Software Development Kit is available for download at www.plxtech.com/sdk. The software development kit includes drivers, source code, and interfaces to aid in configuring and debugging the PEX8605.

Additional PLX Advantages

- Complete and easy to use Software Development Kit
- Schematic and Layout Design Reviews
- Signal integrity testing
- Regional support teams for fast time-to-market

Available on PLX Website:

Product Brief, Databook, Design-in Guidelines, Schematics, OrCAD symbols, Application Notes and more.

- PEX8605 www.plxtech.com/8605