

### PEX 8508 Key Features

- ◆ 8-lane PCI Express switch
- ◆ Integrated SerDes
- ◆ Up to five configurable ports (x1, x2, x4)
- ◆ Cut through architecture with 150ns latency
- ◆ Quality-of-Service with up to 2 Virtual Channels/port
- ◆ Non-blocking switch fabric with full line rates
- ◆ Peer-to-peer switching and host centric data transfers
- ◆ SHPC r1.0 compliant Hot-Plug controller on all ports
- ◆ Dual-clocking support w/ SSC & Constant Frequency domains
- ◆ I<sup>2</sup>C interface for configuration
- ◆ 19x19 mm<sup>2</sup> PBGA package

### PEX 8508 Other Features

- ◆ Selectable Non-Transparent port
- ◆ PCIe Base Specification r1.1 compliant
- ◆ End-to-end CRC
- ◆ Poison bit support
- ◆ Advanced Error Reporting in addition to PCIe Baseline Error Reporting
- ◆ Hardware fixed and Round Robin Virtual Channel Port Arbitration
- ◆ Link power management states: L0, L0s, L1, L2/L3 Ready, L2 & L3
- ◆ 256 byte Max Payload Size
- ◆ Lane and polarity reversal
- ◆ Configuration through strapping pins, I<sup>2</sup>C, EEPROM, or host
- ◆ JTAG Boundary Scan

### Application:

## Control Planes in Telecom Applications

### PLX Product:

## PEX 8508 – 8-Lane 5-Port PCIe Switch

### Key Benefit:

## PCIe Connectivity & Fan-Out

### Telecom Systems Migrating to PCI Express

PCI Express, in addition to storage, server & graphics markets, is now being used in the telecom market. With embedded processors from companies such as Freescale, AMCC and others integrating PCIe ports (in some cases more than 1 PCIe port), telecom applications are beginning to use PCIe on both control & data planes. With non-transparency feature, customers can implement fail-over and/or redundancy in their systems. PCIe is clearly replacing legacy PCI with its ease-of-design & layout, higher throughput with lower latency and lower costs. A typical application would involve a PCIe switch on the line card aggregating traffic from a Network Processor, Traffic Manager, Security Processor, Co-Processor, ASICs etc... over the PCI Express interface. Several such line cards can then be connected, via PCI Express, to the controller card which also has a PCIe switch.

Figure 1 illustrates such an application using PLX PEX 8508, 8-lane 5-port device.

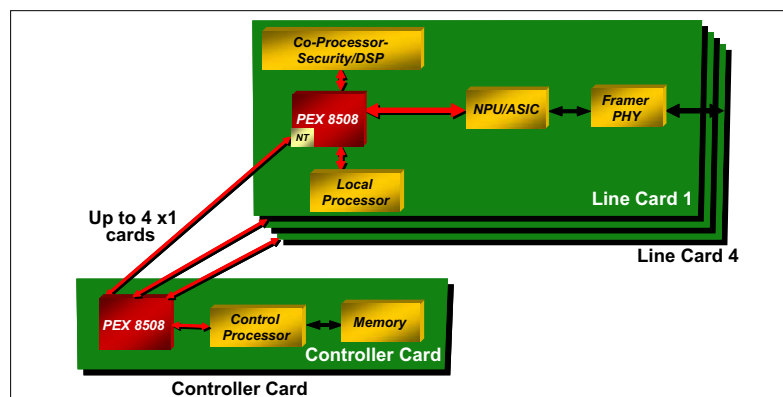

Figure 1: Control Plane Implementation Using PLX PEX 8508

Those applications that need redundancy can use the same line cards shown in figure 1 and design a controller card with two PEX 8508 devices which are connected to each other via the NT port on one of the PEX 8508 devices to provide redundancy.

## Switches & Bridges Available Today!

PLX is shipping three PCIe bridges (PEX 8111, PEX 8114 and PEX 8311) and the PCIe switches listed below.

Device	Lanes	Ports	Availability
PEX 8548	48	9	Sampling
PEX 8532	32	8	In Production
PEX 8524	24	6	In Production
PEX 8516	16	4	In Production
PEX 8518	16	5	In Production
PEX 8517	16	5	In Production
PEX 8508	8	5	In Production

## More than Just Fan Out

- ◆ Cut-through architecture for increased performance
- ◆ Two Virtual Channels for QoS
- ◆ Non-transparent bridging for intelligent adapters, dual-host applications, and failover support

## Design Tools & Documentation:

<http://www.plxtech.com/products/expresslane/pex8508.asp>

Data Book, App Notes, Product Brief, HSPICE/BSDL/IBIS Models, Development Kit

### Contact Information

PLX Technology, Inc.  
 870 Maude Ave.  
 Sunnyvale, CA 94085 USA  
 Tel: 1-800-759-3735  
 Tel: 1-408-774-9060  
 Fax: 1-408-774-2169  
 Applications Support: Local FAE  
 Product Marketing:  
 Krishna Mallampati [kmallampati@plxtech.com](mailto:kmallampati@plxtech.com)  
 Web Site: [www.plxtech.com](http://www.plxtech.com)

© 2006 PLX Technology, Inc. All rights reserved. Expresslane, PLX and the PLX logo are registered trademarks of PLX Technology, Inc. The ExpressLane logo is a trademark of PLX Technology, Inc., which may be registered in some jurisdiction. All other product names that appear in this material are for identification purposes only and are acknowledged to be trademarks or registered trademarks of their respective companies. Information supplied by PLX is believed to be accurate and reliable, but PLX Technology, Inc. assumes no responsibility for any errors that may appear in this material. PLX Technology, Inc. reserves the right, without notice, to make changes in product design or specification.

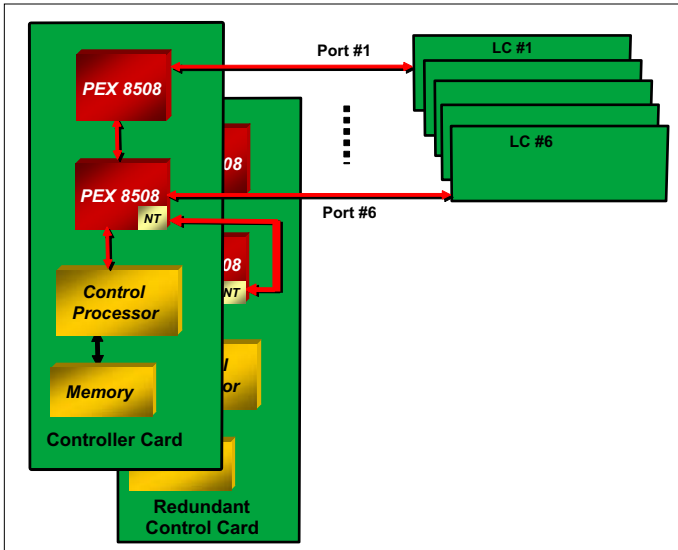

Figure 2: Redundant Control Planes

One additional benefit of figure 2 is the increase in the number of line cards that can be connected – 6 as opposed to 4 in figure 1.

## Flexible & Versatile PCIe Switches

The flexibility and versatility of PLX switches allow designers to build to the needs of their application. The PEX 8508, based on PLX's second generation switch architecture, offers flexible ports that can be configured in any legal width up to x4 while providing high-performance, cut-through architecture (150ns latency), hot-plug capability on every port, and Quality of Service (QoS) through two virtual channel support.

With integrated hot plug controllers, the PEX8508 devices support field replacement with minimum interruption to the data traffic.

The PEX 8508 supports the use of up to four x1 downstream ports with a x4 PCIe upstream port. All PEX 8508 ports support SHPC compliant hot-plug functionality and flexible egress port arbitration. All downstream ports support peer-to-peer communication. The PEX 8508 helps in providing PCIe connectivity between line cards and controller cards through its five flexible ports by allowing any port to be the upstream port and dynamically supporting polarity reversal and lane reversal of the adapter.