



PEX 8311 Key Features

- ◆ Generic Local Bus to PCI Express Bridge
- ◆ Root Complex and EndPoint Modes of Operation
- ◆ Local Bus Modes:
 - 32-bit address & 32-bit data (C-Mode)
 - Multiplexed 32-bit address/data (J-Mode)
- ◆ Local Clock rates up to 66MHz
- ◆ Zero wait state bursts to 264MB/s
- ◆ Integrated SERDES
- ◆ 2 DMA channels
- ◆ 21x21 mm², 337 pin PBGA
- ◆ Typical Power: under 1.0 Watt

Other Features

- ◆ Integrated PCIe Interface
- ◆ Compliant to PCIe r1.0a
- ◆ x1 Link, 2.5 Gbps / direction
- ◆ Auto Polarity Reversal
- ◆ Link CRC Support
- ◆ Link / Device Power Management
- ◆ Flow Control Buffering
- ◆ PCIe Transaction Queues for Eight outstanding TLPs
- ◆ Direct Master Data Transfers
- ◆ Direct Slave Data Transfers
- ◆ Configuration Through Host or Optional EEPROM
- ◆ On-the-fly Endian Conversion
- ◆ 8 Mailbox & 2 Doorbell Registers
- ◆ Four GPIO, 1 GPI, 1 GPO
- ◆ I2O Messaging Unit

Application:

Industrial Controller System

PLX Product:

PEX 8311 – Local Bus to PCIe Bridge

Key Benefit:

Full Connectivity to PCIe components

New Industrial Control Systems Migrating to PCI Express Designs

Industrial control systems have traditionally been extremely limited in their scalability and performance. A typical design would monitor production lines and provide periodic feedback when a parameter falls out of specification. An alarm would be triggered and the line would then be shut down until a corrective action is taken. With economic competition and the need for advanced operations reaching a fever pitch, this method is becoming obsolete. New designs demand real-time feedback and correction without halting production. Factories are routinely providing instantaneous feedback from a variety of sources to a central host for analysis. When an error is detected, only the specific operations are throttled back or stopped. To implement such systems, an intelligent industrial controller analyzes and feeds operations data to a central host through the network. Performance, scalability to industrial strength factories, traffic prioritization, and multiple channels are a must. PCIe interconnect technology fits the need.

PEX 8311 Supports Full Protocol Translations

The PEX 8311 is a bridge from a low overhead parallel generic local bus (used by various processors, DSPs, memory, and FPGA designs) to a PCIe port. In this conversion, the bridge completely translates data from the local bus into PCIe packets with full packet header generation. Address spaces from the local bus and PCIe domain are fully translated. Out-of-band signals on the local bus are translated into message signaling interrupt (MSI) packets and vice versa. The bridge supports all transaction types. Full on-chip buffers provide flow control and the link layer CRC ensures data integrity.

Multiple DMA Channels are Key

Figure 2 shows the PEX 8311 used in an industrial controller. Here multiple sources of analog feedback including infrared, heat, and video images from a production line are converted to digital format and passed to an FPGA for local processing and then through the bridge. The bridge converts traffic to PCIe and passes it through an aggregation switch, such as PLX's PEX 8532, and then passes it to the host controller for analysis and corrective action. FPGA devices routinely use a local bus type interface and connect with no glue logic to the PEX 8311 bridge. As there are multiple streams of data, several bridges are used in the design. A local CPU is used to manage this traffic flow. Memory or other components may also be present on this local bus.

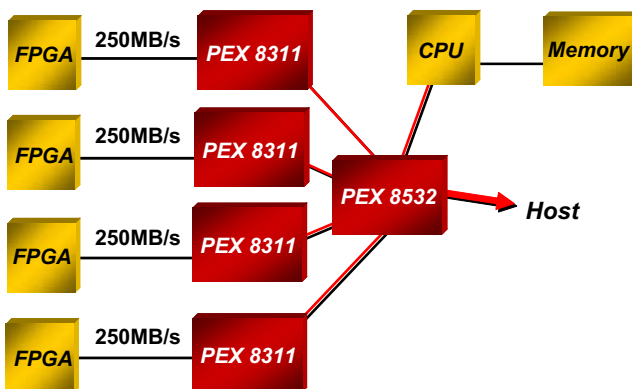

Figure 2

In order to more efficiently transfer data through this system, it is preferable to have multiple DMA channels present. The DMA controllers take a set of instructions from the local CPU or Host and control the transfer of data through the bridge negating the need for host intervention. With two DMA channels present, it simplifies the design as one set of descriptors can be loaded into one DMA channel while the second channel transfers data. In the case of a smaller packet size, throughput can be increased by 30%. A second use of multiple DMA channels is to allow simultaneous bi-directional traffic, in this case, control data from the host back to the source. No need exists to complete one transfer before starting the second.

Additional PEX 8311 Capabilities

Such Industrial Controller Systems often require large numbers of devices present on the local bus and have high bandwidth needs. Local bus devices need to communicate with each other and not just through the bridge. The PEX 8311 has the capability to handle up to five simultaneous loads present on the local bus with up to 32-bit and 66MHz operation.

In addition, the PEX 8311 includes Direct Master and Direct Slave operation simultaneously with DMA. As these modes have higher priority than DMA, they can be used to provide control data or other throughput that cannot be blocked by DMA transfers. To enhance throughput even more, the Read Ahead mode allows data to be obtained and stored in internal FIFOs before it is sent through the bridge.

Design Tools & Documentation:

On PLX Public ToolBox:

http://www.plxtech.com/products/pci_express/PEX8311/default.asp

- ◆ Data Book, BSD, IBIS and HSPICE Models, RDK, OrCAD Symbols and Gerber files.

Contact Information

PLX Technology, Inc.
 870 Maude Ave.
 Sunnyvale, CA 94085 USA
 Tel: 1-800-759-3735
 Tel: 1-408-774-9060
 Fax: 1-408-774-2169
 Applications Support: Local FAE
 Product Marketing:
 Krishna Mallampati
kmallampati@plxtech.com
 Web Site: www.plxtech.com

© 2006 PLX Technology, Inc. All rights reserved. Expresslane, PLX and the PLX logo are registered trademarks of PLX Technology, Inc. The ExpressLane logo is a trademark of PLX Technology, Inc., which may be registered in some jurisdiction. All other product names that appear in this material are for identification purposes only and are acknowledged to be trademarks or registered trademarks of their respective companies. Information supplied by PLX is believed to be accurate and reliable, but PLX Technology, Inc. assumes no responsibility for any errors that may appear in this material. PLX Technology, Inc. reserves the right, without notice, to make changes in product design or specification.

8311-SIL-EA-1.0