

## PEX 8508 Key Features

- ◆ 8-lane PCI Express switch
- ◆ Integrated SerDes
- ◆ Up to five configurable ports (x1, x2, x4)
- ◆ Cut through architecture with under 150 ns latency
- ◆ Quality of Service with up to 2 Virtual Channels/port
- ◆ Non-blocking switch fabric with full line rates
- ◆ Peer-to-peer switching and host centric data transfer
- ◆ SHPC r1.1 compliant Hot-Plug controller on all ports
- ◆ Dual clock domains w/ SSC & Constant Frequency Clocking
- ◆ I<sup>2</sup>C interface for configuration
- ◆ 19x19mm<sup>2</sup> PBGA package

## PEX 8508 Other Features

- ◆ Selectable Non-Transparent bridge port
- ◆ Compliant with PCIe base specification r1.1
- ◆ End-to-end CRC and Poison bit support
- ◆ Basic and Advanced error reporting
- ◆ Hardware fixed and Round Robin packet queue arbitration
- ◆ JTAG boundary scan
- ◆ Link power management states
- ◆ 256 byte payload size
- ◆ Lane and polarity reversal
- ◆ Configuration through host, I<sup>2</sup>C or optional EEPROM
- ◆ JTAG Boundary Scan AC/DC
- ◆ System Error (SERR) Signal

## Application:

### ***Docking Stations***

## PLX Product:

### ***PEX 8508 – 8-Lane PCI Express Switch***

## Key Benefit:

### ***Port Fan-Out and Low Latency***

## Docking Station Migration to PCI Express

In recent years, desktop, laptop and docking station designs have all been PCI based. A traditional PCI-based laptop motherboard consists of an AGP8X bus for graphics, a PCI-based link between the Northbridge and Southbridge, and a PCI bus which services various communications, video, and external devices using protocols such as Gigabit Ethernet and 1349a/b.

As bandwidth requirements have increased, new designs have migrated to the high-speed, point-to-point, serial bus PCI Express

(PCIe) architecture. Today's systems are being designed in with PCIe-based motherboards. The AGP8X bus has been replaced with a x16 PCIe bus, the link between Northbridge and Southbridge is PCIe based, and the external devices serviced by the Southbridge are mostly running on PCIe. This migration to PCIe has had a direct effect on docking stations. The PCI slots on docking stations are expected to be replaced by PCIe slots and the CardBus cards are being replaced by an Express Card.



Docking Station

For a PCI-based docking station, a PCI-to-PCI Bridge was used for fanning out from the primary PCI bus to multiple devices on the secondary side of the PCI bus. Today, this PCI-to-PCI Bridge is being replaced with a PCIe Switch which fans out from the docking connector to multiple PCIe end-points on the docking station (Express Card, PCIe slots, 1394 port, GigE port, etc.).

With the introduction of the PCIe Cable, we also might start to see a change in the docking station connectors. The PCIe Cable is a potential alternative to the traditional docking connectors. Instead of “docking” your laptop onto the docking station, you will just be able to just plug in the PCIe Cable to your laptop via a PCIe Cable port.

## Flexible & Versatile PCIe Switches

PLX offers a large selection of PCIe switches compliant with the latest PCIe specifications; validated in PLX labs; tested at the PCI-SIG plug-fest and by dozens of customers in their applications. The system designers can cost-effectively expand the number of PCIe ports to accommodate a larger number of I/Os and maintain a high performance, low latency design using PLX PCIe switches.

The flexibility and versatility of the PLX switches allows designers to build to the application needs. The PEX 8508, a second generation PCIe switch from PLX, offers flexible ports that can be configured in any legal width up to x4 while providing high-performance, cut-through architecture (150 ns latency); Hot-Plug capability on every port; and Quality of Service (QoS) through two VC support. An example of the PEX 8508 switch in a PCIe-based docking station application is shown below.

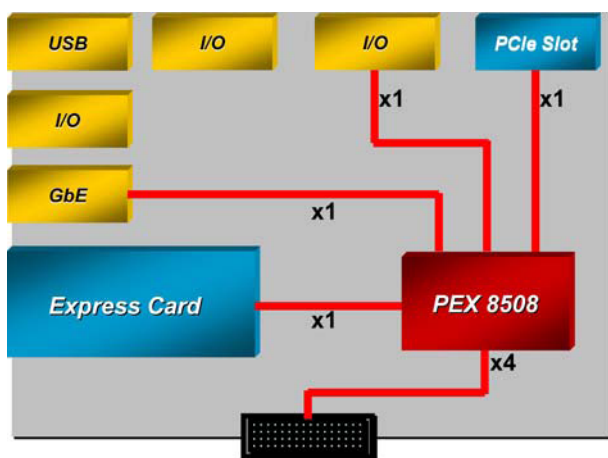

In this example, the PEX 8508 connects to the docking connector (connector interface will vary from design to design) via a x4 upstream port. On the other end, the docking connector will connect to a x4 PCIe port on the laptop's motherboard. The PEX 8508's downstream ports will fan out to an Express Card, a PCIe slot, and another I/O via x1 lanes.

Some docking stations may still continue to carry a PCI slot. In this case, a PEX 8111 can be used to bridge the PCI slot to the PEX 8508.

## Switches & Bridges Available Today!

PLX is shipping three PCIe bridges (PEX 8111, PEX 8114 & PEX 8311) and the PCIe switches as shown below.

Device	Lanes	Ports	Availability
PEX 8532	32	8	In Production
PEX 8524	24	6	Sampling now
PEX 8516	16	4/5	In Production
PEX 8518	16	5	Sampling now
PEX 8508	8	5	Samples in Q2-06

## More than Just Fan Out

- ◆ Cut-through architecture for high-performance
- ◆ Two Virtual Channels for QoS

## Design Tools & Documentation:

[http://www.plxtech.com/products/pci\\_express/PEX8508/default.asp](http://www.plxtech.com/products/pci_express/PEX8508/default.asp)

Data Book, App Notes, Product Brief, Hspice Model, Simulation Model, Development Kit

### Contact Information

PLX Technology, Inc.  
 870 Maude Ave.  
 Sunnyvale, CA 94085 USA  
 Tel: 1-800-759-3735  
 Tel: 1-408-774-9060  
 Fax: 1-408-774-2169  
 Applications Support: Local FAE  
 Product Marketing:  
 Touseef Bhatti [tbhatti@plxtech.com](mailto:tbhatti@plxtech.com)  
 Web Site: [www.plxtech.com](http://www.plxtech.com)

© 2006 PLX Technology, Inc. All rights reserved. Expresslane, PLX and the PLX logo are registered trademarks of PLX Technology, Inc. The ExpressLane logo is a trademark of PLX Technology, Inc., which may be registered in some jurisdiction. All other product names that appear in this material are for identification purposes only and are acknowledged to be trademarks or registered trademarks of their respective companies. Information supplied by PLX is believed to be accurate and reliable, but PLX Technology, Inc. assumes no responsibility for any errors that may appear in this material. PLX Technology, Inc. reserves the right, without notice, to make changes in product design or specification.