

PEX 8114 Key Features

- ◆ Transparent and Non-Transparent Modes
- ◆ Forward and Reverse Modes
- ◆ Low Power Consumption (2W)
- ◆ Small Footprint 17 x 17 mm BGA Package
- ◆ Lead Free Available
- ◆ Supports PCI and PCI-X 33MHz thru 133MHz

Other Important Features

- ◆ No heat sink required
- ◆ EEPROM Configuration Option
- ◆ DC and AC JTAG
- ◆ Fully-Integrated PCIe PHY
- ◆ Supports x1, x2 and x4 Links
- ◆ Automatic Lane Reversal
- ◆ 256 Byte Max Payload Size
- ◆ End-to-End CRC
- ◆ Poison Bit Support
- ◆ Hot Plug
- ◆ MSI Support
- ◆ Internal Arbiter Supports Up to 4 Masters
- ◆ External Arbiter Support
- ◆ Advanced Error Reporting
- ◆ Unused Lanes Powered Down
- ◆ Link and Device Power Management
- ◆ 8 Outstanding Split Transactions
- ◆ Provides Up to 4 PCI/PCI-X Clocks
- ◆ Advanced Flow Control
- ◆ Listed on PCI SIG Integrator's list for PCIe and PCI/PCI-X Compliance

Application:

Quad T1 Communications Processor Card

PLX Product:

PEX 8114 ExpressLane PCIe to PCI-X Bridge

Key Benefit:

Smart Communications Card Offloads Processing from Host

New T1 Line Cards Deploy PCI Express for Higher Throughput

With the capacity requirements of telecom networks ever increasing, there are two trends to allow higher system throughput: (1) Offloading the communications processing from the host to the NIC, and (2) the transition from PCI to PCI Express. Offloading the communications processing, such as compression and decoding, from the system host allows the system to operate with more efficiency and hence increased traffic capacity. Because of its performance scalability and protocol advances, PCIe-based systems are faster and more reliable than their PCI-based counterparts.



These transitions are complicated in the fact that a processor on the line card will tend to be enumerated by the system host. This processor needs to be isolated from the host to prevent this. In addition, most communications processors on the market today are PCI-native. So there are two problems to solve: isolating the line card's processor and bridging it from PCI to PCI-Express.

Offload Network Processing from the Host

The solution is found in a single device from PLX: The PEX 8114 PCI Express to PCI-X ExpressLane bridge. This device bridges the PCI (or PCI-X) bus on the network processor to PCI Express for enhanced bandwidth. This is the only PCI Express Bridge to feature Non-Transparent mode.



Non-Transparent Mode Lets the Card Do the Heavy Lifting

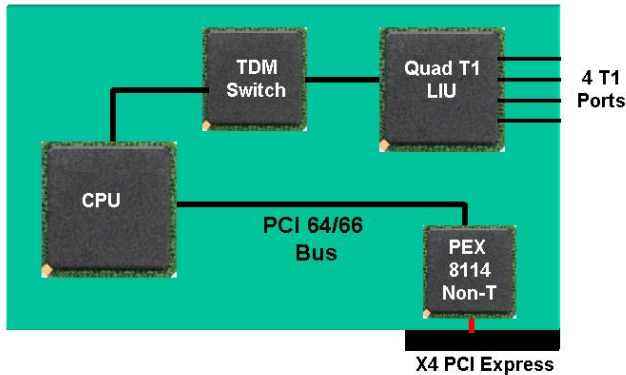

Here's a closer look at the Quad T1 Line Card design. With the PEX 8114 in Non-Transparent (Non-T) mode, the card appears as an endpoint to the host, and hence the host does not try to look through the bridge as it would if it were in Transparent-mode. In Non-T mode, the PEX 8114 provides a window through which the host can pass data into a translated address space. Communication CSRs, including doorbell and scratchpad are used to set up and define the behavior of the signaling and messaging interfaces used by the host and local processors to communicate with each other.

The PEX 8114 is Optimized for These Applications:

- ◆ PCI-X Conversion to PCIe
- ◆ Adding PCI-X Slots to a PCIe System
- ◆ Adding PCIe Slots to a PCI-X System
- ◆ PCIe Hot Swap Cards
- ◆ High Performance ATCA and AMC Card

Lead Free Packaging NOW!

The PEX 8114 is available in lead-free ROHS-compliant versions as well as the traditional leaded packages.

Part Number	Package	Speed
PEX 8114-BA13BI	Standard Leaded BGA Package	133 MHz
PEX 8114-BA13BI G	Lead-Free ROHS Green BGA Packaging	133 MHz

PLX Advantages

- ◆ The industry's best PCI Express expertise and support
- ◆ Low Power (2W)
- ◆ Small Footprint

Design Tools & Documentation: On PLX Public Toolbox:

http://www.plxtech.com/products/pci_express/PEX8114/default.asp

- ◆ DataBook, IBIS Models, App Notes, Product Brief, Hspice Models

Contact Information

PLX Technology, Inc.
 870 Maude Ave.
 Sunnyvale, CA 94085 USA
 Tel: 1-800-759-3735
 Tel: 1-408-774-9060
 Fax: 1-408-774-2169
 Applications Support: Local FAE
 Product Marketing:
 Steve Moore smoore@plxtech.com
 Web Site: www.plxtech.com

© 2006 PLX Technology, Inc. All rights reserved. PLX and the PLX logo are registered trademarks of PLX Technology, Inc. ExpressLane, PowerDrive and the PowerDrive logo are trademarks of PLX Technology, Inc., which may be registered in some jurisdiction. All other product names that appear in this material are for identification purposes only and are acknowledged to be trademarks or registered trademarks of their respective companies. Information supplied by PLX is believed to be accurate and reliable, but PLX Technology, Inc. assumes no responsibility for any errors that may appear in this material. PLX Technology, Inc. reserves the right, without notice, to make changes in product design or specification.

8114-SIL-EA-1.0