

PEX 8518 Key Features

- ◆ 16-lane PCI Express switch
- ◆ Integrated SerDes
- ◆ Up to five configurable ports (x1, x2, x4, x8)
- ◆ Cut through architecture with 150 ns latency
- ◆ Quality-of-Service with up to 2 Virtual Channels/port
- ◆ Non-blocking switch fabric with full line rates
- ◆ Peer-to-peer switching and host centric data transfer
- ◆ SHPC r1.1 compliant hot-plug controller on all ports
- ◆ Dual clock domains with SSC and constant frequency
- ◆ I²C interface for configuration
- ◆ 23 x 23 mm² PBGA package

PEX 8518 Other Features

- ◆ Selectable Non-Transparent bridge port
- ◆ Compliant with PCIe base specification r1.1
- ◆ End-to-end CRC and Poison bit support
- ◆ Basic and Advanced error reporting
- ◆ Hardware fixed and Round Robin packet queue arbitration
- ◆ JTAG boundary scan
- ◆ Link power management states
- ◆ 256 byte payload size
- ◆ Lane and polarity reversal
- ◆ Configuration through host or optional EEPROM
- ◆ JTAG Boundary Scan AC/DC

Application:

Advanced Mezzanine Card (AMC)

PLX Product:

PEX 8518 – 16-Lane PCI Express Switch

Key Benefit:

Expands PCIe Ports & End Points

New PICMG Standard for AMC

The AMC Modules are attracting many users due to their versatility and upgradeability. The AMC Modules can be plugged into the AdvancedTCA systems, MicroTCA systems or any chassis that uses the AMC form factor and interfaces.

Historically, AMC modules would plug into a carrier module (shown on right) for installation in the AdvancedTCA chassis. This was prohibitive as partially filled carrier modules and chassis did not make economic sense for many applications.

The PICMG Forum is creating a new standard, the MicroTCA chassis (shown on right), allowing AMC modules to be directly connected to the switch fabric or host module through backplane interface. The MicroTCA standard can be used to build chassis in various form factors (width/height) based on the need of the application or user.

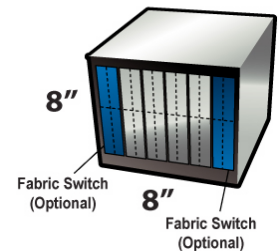

PCIe Switches for connectivity & expansion

The PCI Express technology has been adopted by the PICMG Forum as specified in the AMC.1 standard. This standard allows use of PCIe on the backplane and switch fabric. As AMC modules directly connect to the backplane, the PCIe switches may be used in the AMC modules to expand backplane interface and in the switch fabric module to provide control plane and/or data plane switching. Non-PCIe components or I/Os may be connected to the switches through PCIe bridge devices widely available in the industry.

Flexible & Versatile PCIe Switches

PLX offers a large selection of PCIe switches compliant with the latest PCIe specifications; validated in PLX labs; and tested by dozens of customers in their applications. Using PLX PCIe switches, the system designers can cost effectively expand the ports available on the chassis backplane to a larger number of I/Os on the AMC module.

The flexibility and versatility of the PLX switches allows designers to build to the needs of the application. The PEX 8518, a second generation PCIe switch from PLX, offers flexible ports that can be configured in any legal width up to x8 while providing high-performance, cut-through architecture; Hot Plug capability on every port; and Quality of Service (QoS) through two virtual channels (VCs).

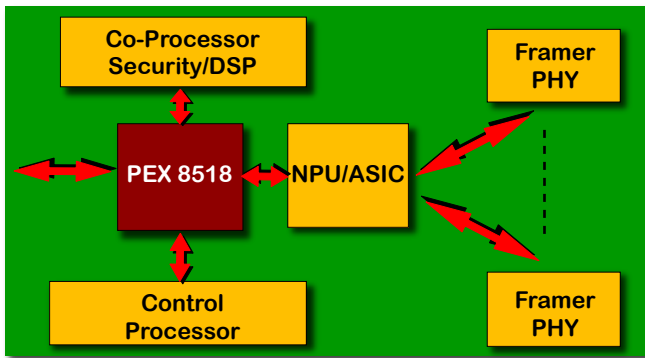

The promise of the MicroTCA and AdvancedTCA is that AMC modules, switch fabrics and chassis from different vendors will interoperate with each other seamlessly. The PEX 8518 switch helps deliver on this promise through its five flexible ports allowing any port to be upstream and dynamically adopt to the LVDS polarity (polarity reversal) and lane orientation (lane reversal). Additionally, PEX 8518 can be directly connected to the host PCIe port or via the root complex. The non-transparent bridge port of the PEX 8518 allows use of redundant fabrics or dual hosts in the system.

Switches & Bridges Available Today!

PLX is shipping three PCIe bridges (PEX 8111, PEX 8114 & PEX 8311) and the PCIe switches as shown below.

Device	Lanes	Ports	Availability
PEX 8532	32	8	In Production
PEX 8524	24	6	Sampling now
PEX 8516	16	4	In Production
PEX 8518	16	5	Samples in Q1-06
PEX 8508	8	5	Samples in Q1-06

More than Just Fan Out

- ◆ Cut-through architecture for high performance
- ◆ Two Virtual Channels for QoS
- ◆ Non-transparent bridging for multi-host

Design Tools & Documentation:

http://www.plxtech.com/products/pci_express/PEX8518/default.asp

Data Book, App Notes, Product Brief, Hspice Model, simulation model, Development Kit

Contact Information

PLX Technology, Inc.
 870 Maude Ave.
 Sunnyvale, CA 94085 USA
 Tel: 1-800-759-3735
 Tel: 1-408-774-9060
 Fax: 1-408-774-2169
 Applications Support: Local FAE
 Product Marketing:
 Akber Kazmi akazmi@plxtech.com
 Web Site: www.plxtech.com

© 2005 PLX Technology, Inc. All rights reserved. PLX and the PLX logo are registered trademarks of PLX Technology, Inc. ExpressLane, PowerDrive and the PowerDrive logo are trademarks of PLX Technology, Inc., which may be registered in some jurisdiction. All other product names that appear in this material are for identification purposes only and are acknowledged to be trademarks or registered trademarks of their respective companies. Information supplied by PLX is believed to be accurate and reliable, but PLX Technology, Inc. assumes no responsibility for any errors that may appear in this material. PLX Technology, Inc. reserves the right, without notice, to make changes in product design or specification.