

PEX 8111 Key Features

- ◆ Small Package Size
 - 10x10mm Fine-Pitch BGA
 - 13x13mm Std-Pitch BGA
- ◆ Low Power (400mW)
- ◆ Single (x1) PCI Express Lane
- ◆ 32-bit/66 MHz PCI Interface
- ◆ Supports Both Forward- and Reverse-Mode PCI Express to PCI Bridging

Other Features

- ◆ Large 8KB Internal FIFO
- ◆ 128 byte maximum PCI Express payload size
- ◆ 3.3V I/O and 5V tolerant PCI
- ◆ PCI Express Flow Control Buffering
- ◆ Eight (8) outstanding PCI Express Transactions
- ◆ Completely integrated PCI Express PHY
- ◆ External EEPROM configuration option
- ◆ Four (4) GPIO pins for maximum design flexibility
- ◆ JTAG
- ◆ External arbiter or internal programmable arbitration for up to four bus masters
- ◆ Option to provide PCI clock
- ◆ Supports PCI and Virtual Interrupts (MSI)
- ◆ Lead-free packaging also available

Application:

PCI Express Digital Video Recorder (DVR) Cards

PLX Product:

PEX 8111 – x1 PCIe-to-PCI Bridge

Key Benefit:

Easy Upgrade to PCI Express

Video Controller Silicon is PCI based

The DVR cards on the market today ship in the form of PCI add-in cards. With the increasing number of PCIe based PCs now shipping, the number of PCI slots is slowly diminishing. The next generation DVR card is migrating to PCIe as more PCIe systems hit the market. However, today's video controller silicon is PCI based and designing a PCIe native video controller is expensive. The DVR manufacturers can't wait for the video controller silicon designers to develop a PCIe native version.

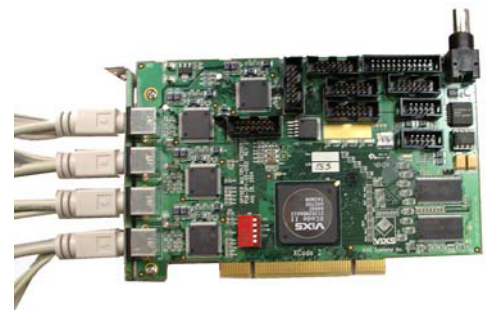

Quick and Easy Solution: Use a PCI to PCIe Bridge

Actually, the DVR manufacturers do not have to wait for a PCIe native video controller. They can turn their existing PCI DVR card into a PCIe DVR card with one additional chip. The PEX 8111 was developed for opportunities like this.

The PEX 8111 supports up to a 66MHz 32-Bit PCI bus and converts it to a single x1 lane of PCI Express in Forward Mode. In Reverse Mode, the PEX 8111 allows PCIe native silicon to bridge back to a legacy PCI system.

DVR manufacturers can quickly and easily broaden their product line with the PEX 8111 in Forward mode. Thus, they will have a DVR card fit for any system covering both the PCI and PCIe market.

PCI native DVR card:

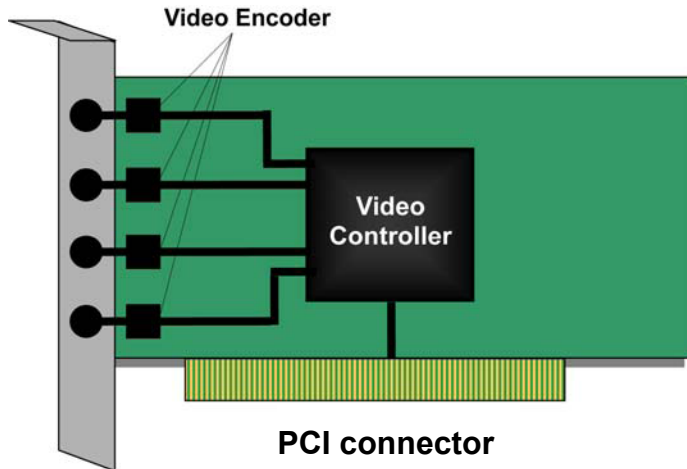

PCIe native DVR card:

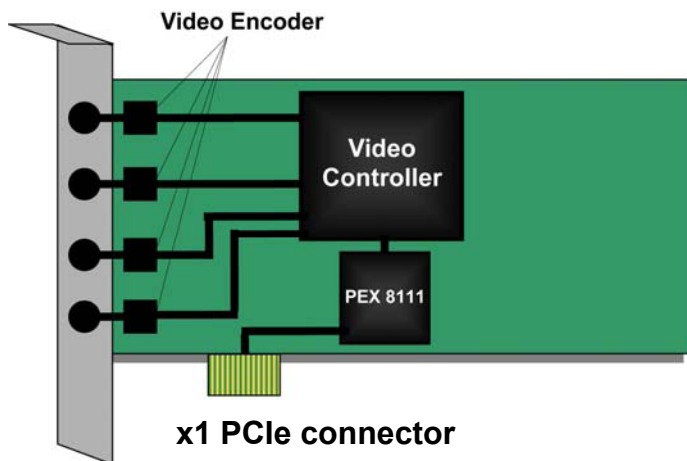

The addition of the PEX 8111 requires only 1 square centimeter of additional board real estate to convert the PCI interface to a single x1 lane PCIe. In addition, the bridge only draws 400 milliwatts of additional power. The small footprint, low power consumption and low cost of the PEX 8111 make it an ideal fit for this application.

Shipping NOW!

The PEX 8111 is in production today and samples are in stock at PLX. In addition, Rapid Development Kit (RDK) boards are in stock. These boards allow a quick evaluation of your design concept without having to lay out your own board.

The PEX 8111RDK offers a known, working hardware environment. For example, you can take your existing PCI Card and plug it into this card to prove out the concept. The RDK will be able to plug into a PCI Express socket with your card on the other side of the bridge. RDK boards are available for both forward and reverse mode operation.

Key Advantage of using PLX

PLX is the industry's leading supplier of PCI Express Switches and Bridges. The company is focused on the design and support of silicon in the first wave of PCI Express systems. PLX also offers a PCI Bus to USB 2.0 Bridge chip that converts PCI native devices into a USB solution.

Design Tools & Documentation:

On PLX Public ToolBox:

http://www.plxtech.com/products/pci_express/PEX8111/default.asp

- ◆ Data Book, Product Brief, IBIS Models, HSPICE Models, BSDL Files

Contact Information

PLX Technology, Inc.
 870 Maude Ave.
 Sunnyvale, CA 94085 USA
 Tel: 1-408-774-9060
 Applications Support: Local FAE
 Product Marketing:
 Eugene Cabanban
ecabanban@plxtech.com
 Web Site: www.plxtech.com

© 2005 PLX Technology, Inc. All rights reserved. PLX and the PLX logo are registered trademarks of PLX Technology, Inc. ExpressLane, PowerDrive and the PowerDrive logo are trademarks of PLX Technology, Inc., which may be registered in some jurisdiction. All other product names that appear in this material are for identification purposes only and are acknowledged to be trademarks or registered trademarks of their respective companies. Information supplied by PLX is believed to be accurate and reliable, but PLX Technology, Inc. assumes no responsibility for any errors that may appear in this material. PLX Technology, Inc. reserves the right, without notice, to make changes in product design or specification.

8111-DVR-EA-1.0