

PEX 8111 Key Features

- ◆ Supports Both Forward- and Reverse-Mode PCI Express to PCI Bridging
- ◆ Small Package Size
 - 10x10mm Fine-Pitch BGA
 - 13x13mm Std-Pitch BGA
- ◆ Low Power (400mW)
- ◆ Single (x1) PCI Express Lane
- ◆ 32-bit/66 MHz PCI Interface

Other Features

- ◆ Large 8KB Internal FIFO Completely integrated PCI Express PHY
- ◆ 128 byte maximum PCI Express payload size
- ◆ PCI Express Flow Control Buffering
- ◆ Eight (8) outstanding PCI Express Transactions
- ◆ External EEPROM configuration option
- ◆ Four (4) GPIO pins for maximum design flexibility
- ◆ 3.3V I/O and 5V tolerant PCI
- ◆ JTAG
- ◆ External arbiter or internal programmable arbitration for up to four bus masters
- ◆ Option to provide PCI clock
- ◆ Supports PCI and Virtual Interrupts (MSI)
- ◆ Lead-free packaging also available

Application:

High Performance PCI Graphics Card using PCI Express Native Silicon

PLX Product:

PEX 8111 – x1 PCIe-to-PCI Bridge

Key Benefit:

PCIe-Native Silicon Can Interface with Legacy PCI Systems

PCI 8111 Reverse-Bridging Feature Connects Legacy PCI Systems to Leading Edge Express-Based Silicon

Next-generation graphics accelerators are now being developed with PCI Express-native silicon. Where these chips once had AGP or PCI interfaces, they now use PCI Express interfaces. This creates a problem for graphics add-in card manufacturers: they want to be able to deploy the latest and greatest graphics feature sets, and still be able to sell their cards into the huge existing market for systems that use the PCI bus. Reverse-Mode Bridging solves this problem. It allows the PCIe-native silicon to be mastered by a PCI bus. The PEX 8111 is the only single-lane PCIe-to-PCI bridge to offer Reverse-Mode Bridging.



Why Not Deploy PCI-Native Silicon?

Three answers: (1) performance, (2) pin count (footprint) and (3) cost. The transfer rate performance of PCIe is much higher than PCI. For example, the maximum transfer rate through a 32-bit/33MHz PCI bus is 133Mb/s. The x1 PCIe link supports almost twice that rate, up to 250MB/s. Consider the second reason, footprint. The pin count for a 32-bit PCI interface is over 40 pins, whereas a x1 PCIe link only



requires 4 pins. The results in a smaller footprint, meaning smaller packaging lower cost. So why spend development cost on a new PCI device when the function is achieved by adding a reverse-mode bridge?

Reverse Bridging in the Smallest Footprint

The PEX 8111 enables designers to quickly and easily PCI-based cards using PCIe native silicon. The addition of the PEX 8111 requires only *1 square centimeter* of additional board real estate to convert the PCIe interface to legacy PCI. In addition, the bridge only draws 400 milliwatts of additional power.

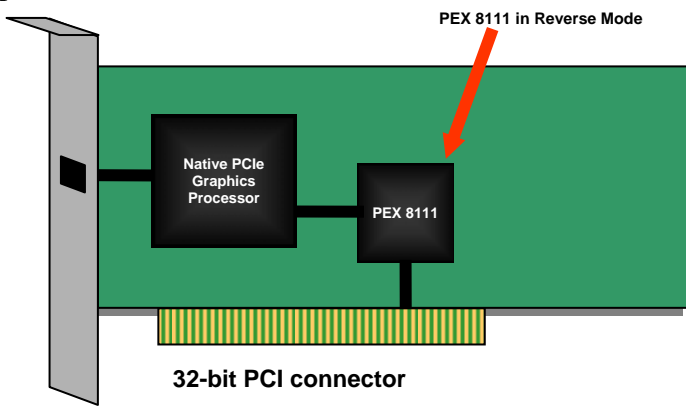

Key Advantage of Using PLX

PLX is the industry's leading supplier of I/O interconnect Switches and Bridges for PCI Express. The company is focused on the design and support of silicon in the first wave of PCI Express systems.

Test Design Concept Now With Rapid Development Kit

The PEX 8111 Reverse Mode Rapid Development Kit (PEX 8111 RDK-R) provides a quick utility to prove out your design concept. The RDK offers a known, working hardware environment similar to the design of PCI components behind the PCI Express-to-PCI Bridge.

Additional PLX Advantages

- ◆ Superior PCI Express design expertise and support
- ◆ The PEX 8111 is fully certified by the PCI SIG and is listed on its Integrator's list for PCI Express.
- ◆ PEX 8111 also operates as Forward-Mode Bridge

Design Tools & Documentation:

On PLX Public ToolBox:

http://www.plxtech.com/products/pci_express/PEX8111/default.asp

- ◆ Data Sheet, Product Brief, IBIS Models, HSPICE Models, BSDL Files

The figure below compares forward-mode and reverse-mode bridging.

Contact Information

PLX Technology, Inc.
 870 Maude Ave.
 Sunnyvale, CA 94085 USA
 Tel: 1-800-759-3735
 Tel: 1-408-774-9060
 Fax: 1-408-774-2169
 Applications Support: Local FAE
 Product Marketing:
 Steve Moore smoore@plxtech.com
 Web Site: www.plxtech.com

© 2005 PLX Technology, Inc. All rights reserved. PLX and the PLX logo are registered trademarks of PLX Technology, Inc. ExpressLane, PowerDrive and the PowerDrive logo are trademarks of PLX Technology, Inc., which may be registered in some jurisdiction. All other product names that appear in this material are for identification purposes only and are acknowledged to be trademarks or registered trademarks of their respective companies. Information supplied by PLX is believed to be accurate and reliable, but PLX Technology, Inc. assumes no responsibility for any errors that may appear in this material. PLX Technology, Inc. reserves the right, without notice, to make changes in product design or specification.

8111-Graphics-EA-1.0