

PEX 8532 Key Features

- ◆ 32-lane PCI Express Switch
- ◆ Up to 8 flexible ports
- ◆ Non-Transparent bridging for dual fabric or control modules
- ◆ Quality of Service through Two VCs and Eight TCs
- ◆ Large packet buffer
- ◆ Hot-Plug on every port
- ◆ 35mm x 35mm BGA package
- ◆ Compliant with the PCI-SIG PCIe specification rev 1.0a

Other Features

- ◆ Highly configurable ports in x1, x2, x4, x8 and x16 port widths
- ◆ Strapping signals for port configuration
- ◆ Any port could be upstream port and hot-plug master/slave
- ◆ Lane and polarity reversal
- ◆ Large Packet Memory
- ◆ 32 General Purpose Outputs
- ◆ Auto port width negotiation
- ◆ Peer-to-peer and host centric data transfer
- ◆ Hardware fixed and Round Robin packet queue arbitration
- ◆ Fully non-blocking internal fabric supporting full line-rate
- ◆ 256 Byte maximum packet size
- ◆ Basic and Advanced error reporting
- ◆ End-to-end CRC and poison bit support
- ◆ Configuration through host or optional EEPROM

Application:

High-end Routers

PLX Product:

PEX 8532 – Versatile PCI Express Switch

Key Benefit:

High Throughput & Terabit Performance

Deep packet processing requirement drives the need for PCI Express interconnect



High-end routers process millions of packets per second in order to support ever increasing demand for speed and real-time response by modern applications. These routers perform deep packet processing for authentication, security, quality of service, reliability, route optimization and network management. Several application specific processors or custom ASICs are involved in packet processing. These processors need to be interconnected through efficient high-speed, chip-to-chip or board-to-board, interconnects. Typically, routers consist of line cards, router/switch modules and control modules. An example of a line card with PCI Express as interconnect technology is shown above.

High-end routers process millions of packets per second in order to support ever increasing demand for speed and real-time response by modern applications. These routers perform

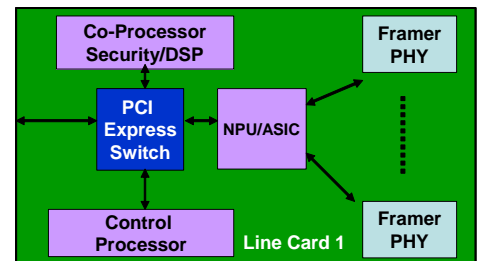

The PEX 8532 Switch

The PLX PCI Express Switches can be used on the Line Cards, Switch module and Control Modules. PCI Express technology is backward compatible with PCI based software that is used in router operating systems. The PEX 8532 device supports 32 high-speed (2.5 Gb/s each direction) lanes and up to 8 PCI Express ports. The device allows cascading of multiple switches to offer any number of ports needed. PEX 8532 also offers peer-to-peer transfer that enables the Line Cards to pass packets to each other without Control Module involvement.

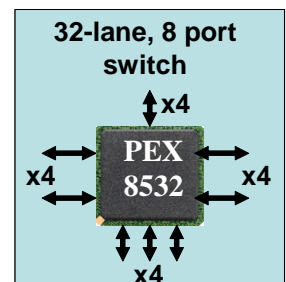

Additionally, internal queuing avoids head of the line blocking and switch fabric architecture supports full line rate on all ports.

The ExpressLane PEX 8532 & PEX 8516 Solution

The PEX 8532 32-lane switch can be used in switch fabrics as well as line cards and the PEX 8516 16-lane switch can be used on the line card to connect a network processor and a security processor using PCI Express technology. The line cards can be connected to the switch fabric that uses PEX 8532s as shown below. The control and data planes can be isolated using two different switch devices as shown below.

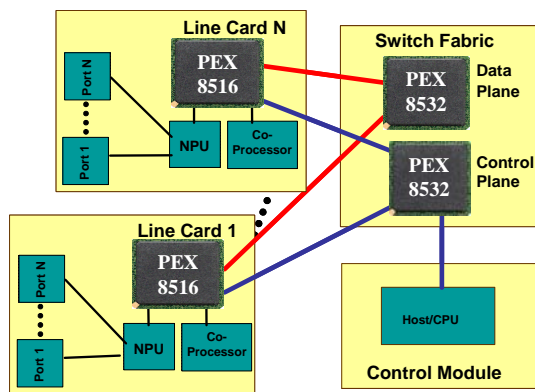

PEX 8532 & PEX 8516 support two Virtual Channel allowing prioritization of traffic for Quality of Service support within each plane.

Furthermore, PLX PCI Express switches offer non-transparent bridging function that allows isolation of two switch fabric modules or control modules. The dual fabric or dual control modules can operate in load-sharing or in fail-over mode. The non-transparent bridge function enables use of PCI Express in high-availability applications.

Key Advantages for PLX

The ExpressLane PEX 8532 is the most versatile and flexible PCI Express switch in the industry. It provides advance features such as flexible port

Issue No. 10

configuration, non-transparent bridging, peer-to-peer data transfer, large on-chip packet memory, two virtual channels and advanced error reporting in a compact BGA package at affordable cost.

Maximize Performance

The packet buffers in PEX 8532 are not allocated to any specific port instead the architecture is based on the centralized packet memory. This allows optimum use of the packet memory based on dynamic buffer assignment by the user for specific ports.

Additional PLX Advantages

- ◆ Broad PCI Express product portfolio that includes switches & bridges
- ◆ Core competency in PCI Express technology & leadership in developing PCIe specifications & eco-system
- ◆ Evangelizing and leading efforts in several Industry forums for PCI Express adoption

Design Tools & Documentation:

On PLX Public Tool Box:

http://www.plxtech.com/products/pci_express/PEX85xx/default.asp

- ◆ DataBook, App Notes, Product Brief
- ◆ Hspice Models, IBIS Models, BSD Files,

Contact Information

PLX Technology, Inc.
 870 Maude Ave., Sunnyvale, CA 94085 USA
 Tel: 1-800-759-3735
 Tel: 1-408-774-9060
 Applications Support: Local FAE
 Product Marketing: Akber Kazmi
akazmi@plxtech.com
 Web Site: www.plxtech.com

© 2005 PLX Technology, Inc. All rights reserved. PLX and the PLX logo are registered trademarks of PLX Technology, Inc. ExpressLane, PowerDrive and the PowerDrive logo are trademarks of PLX Technology, Inc., which may be registered in some jurisdiction. All other product names that appear in this material are for identification purposes only and are acknowledged to be trademarks or registered trademarks of their respective companies. Information supplied by PLX is believed to be accurate and reliable, but PLX Technology, Inc. assumes no responsibility for any errors that may appear in this material. PLX Technology, Inc. reserves the right, without notice, to make changes in product design or specification.

6150-SIL-EA-1.0 3/05