

OXUF943SE, FireWire 800 or USB 2.0 to SATA Controller with Encryption

OXUF943SE Highlights

■ General Features

- High performance, low power SATA storage controller with Encryption

■ Key Features

- High performance, low power SATA storage controller with Encryption
- Integrated 480 Mbps USB 2.0 high speed core and PHY
- Market proven 1394b PHY interface and Link Layer with industry leading performance
 - Supports PHY power down modes
- Integrated SATA II compliant core and PHY
 - Supports 3.0 Gbps and 1.5 Gbps interfaces
 - Supports Interface Power Management (IPM)
- Integrated hardware cipher engine supporting AES encryption / decryption (over USB and FireWire):
 - Support for 128-bit and 256-bit keys
 - Support for AES-ECB and AES-CBC algorithms
 - Support for AES-XTS as defined by IEEE P1619
 - Host software and driver supplied for password application for PC and Mac
- SPI interface for serial flash
- 19 GPIOs allow easy product customization
- Support for USB Human Interface Device (HID)
- Support for button push apps



The OXUF943SE is a high performance, low power storage controller optimized for secure personal storage applications, bridging between FireWire 800 or USB 2.0 interface to a single SATA hard disk.

Optimized for bus-powered applications, the OXUF943SE supports a number of power saving modes, including SATA Interface Power Management (IPM), which allows additional power saving when connected to an HDD that also supports IPM.

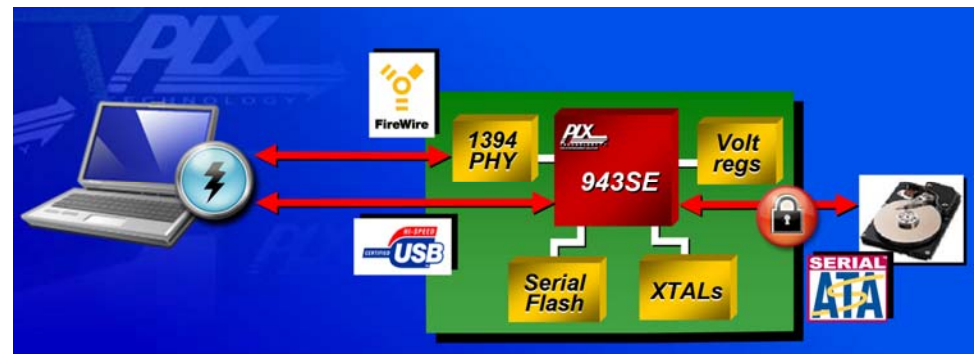

The integrated cipher engine provides advanced encryption and decryption capabilities in hardware and enables OEMs to rapidly deploy full disk encryption solutions, providing end users with peace-of-mind that their private content is safe and secure in the event of theft or loss.

Integrating a USB 2.0 device, a FireWire 800 link layer, and a SATA host controller, the OXUF943SE enables designers to create products with a minimal number of external components and a low cost BOM.

Embedded ARM Processor

By managing the data flow, the on-chip ARM7 processor enables a whole new series of standalone consumer electronic product to be developed in a simple C/C++ programming environment.

USB2.0

The embedded USB 2.0 PHY supports both full and high speed, using bulk-only transport Mass Storage Class device protocol. OXUF943SE's fast read and write transfers ensure that the maximum possible host performance is maintained. No additional USB host drivers are required, for either Windows® or Mac® operating systems, for standard storage, button notification or GPIO control applications.

FireWire

The embedded 1394 PHY and link layer supports FireWire 800, is backward compatible with FireWire 400 and complies with the 1394-1995 and 1394-2000 specifications. No additional 1394 host drivers are required for either Windows or Mac operating systems for standard storage applications.

SATA Interface

The embedded 3 GHz SATA host interfaces supports the latest revisions of the SATA II specifications. Interface speeds of 3 GHz and 1.5 GHz deliver maximum performance with minimum latency for external SATA storage.

OXUF943SE, FireWire 800 or USB 2.0 to SATA Controller with Encryption

Encryption

The integrated hardware cipher engine supports real-time, on-the-fly encryption / decryption of the data to the Advanced Encryption Standard (AES), providing a means whereby a users' data can be securely stored, and made unavailable to unauthorized users.

The cipher engine can be configured for the following AES algorithms:

- ECB – Electronic Code Book
 - Simplest implementation of the AES algorithm
 - Fully NIST / FIPS140-2 approved algorithm
- CBC – Cipher Block Chaining
 - Feeds forward encrypted data to produce a stronger cipher-text result than ECB
 - Fully NIST / FIPS140-2 approved algorithm
- XTS – XEX-based Tweaked CodeBook with CipherText Stealing
 - Variant of AES developed for protecting data at rest, also known as IEEE P1619

In addition to a high-performance cipher engine, the OXUF943SE is complemented by robust authentication solutions, including software password. A customizable host application, the PLX Technology Authenticator, is provided for both PCs and Mac hosts to:

- Define and manage up to 10 passwords
- Authenticate and mount the drive
- Safely de-authenticate and un-mount the drive

Block Diagram

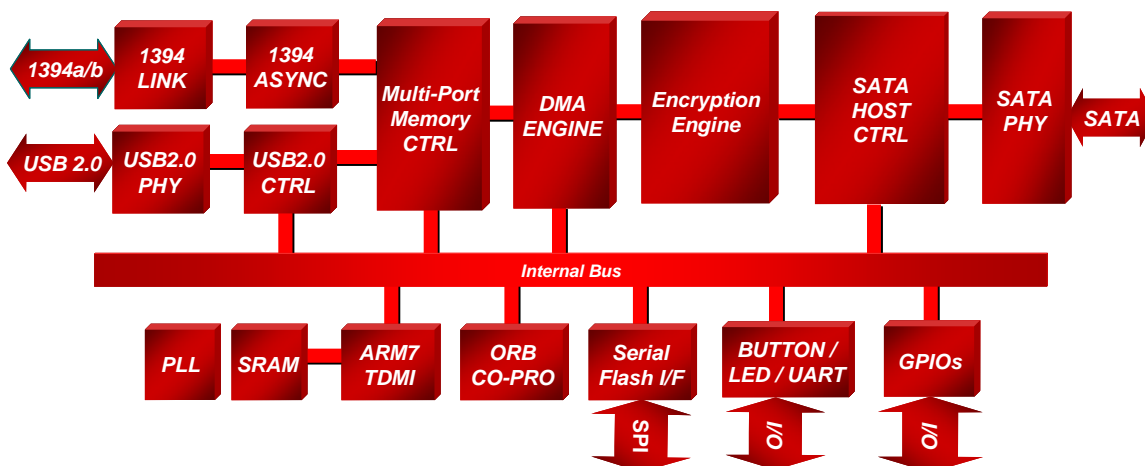

Development Support

For external Mac and PC storage solutions, PLX Technology offers a comprehensive support package including:

- Reference designs comprising both hardware and software components
- Evaluation boards with pre-built application firmware
- Software Development Kit (SDK) comprising source code and debug boards
- Extensive range of application notes to shorten learning curves and simplify implementation

Product Ordering Information

Part Number	Description
OXUF943SE-LQCG	FireWire 800, USB 2.0 to SATA controller with Encryption

Product Documentation

<http://www.plxtech.com/OXUF943SE>

PLX Technology, Inc. All rights reserved. PLX and the PLX logo are trademarks of PLX Technology, Inc. All other product names that appear in this material are for identification purposes only and are acknowledged to be trademarks or registered trademarks of their respective companies. Information supplied by PLX is believed to be accurate and reliable, but PLX assumes no responsibility for any errors that may appear in this material. PLX reserves the right, without notice, to make changes in product design or specification.

Visit www.plxtech.com for more information.